

Designed to withstand exterior environments and wind loading, the 150F Exterior metal ceiling system is ideal for soffits and facades.

Project: Bill and Hillary Clinton National Airport, Little Rock, AR; 150F Linear Metal Soffit System Photo credit: Bob Perzel

KEY FEATURES

- Panel width: 6" nom. [150 mm]
- Panel lengths: 3' to 20'
- Panel depth: 1 1/16"
- Waste reduction with factory fabricated dimensional material
- Downweight: reduce dead load with lightweight aluminum
- Interior and exterior applications
- Compatible with industry standard lighting, HVAC, speaker, fire safety, and security services
- Luxacote® high-performance finish resists exterior environmental conditions including UV
- Perforated panels are available only for exterior ventilation and may not exceed 10% of the total ceiling area
- Factory assembled access doors available
- Miami-Dade County, FL NOA No. 14-1222.04 (expires March 19, 2020)

TYPICAL SECTIONS

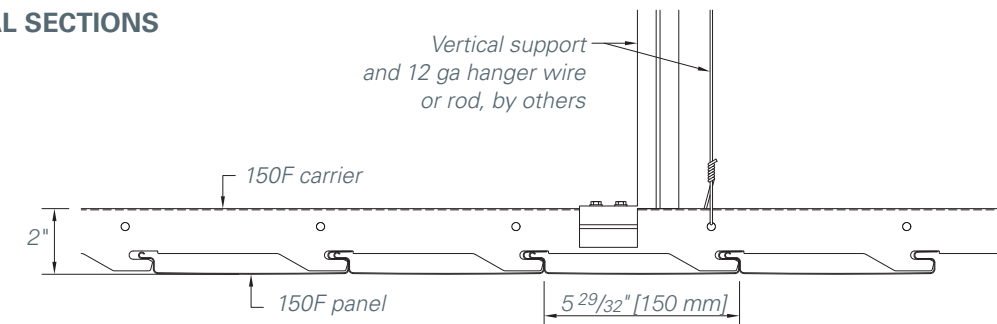

TYPICAL ISOMETRIC

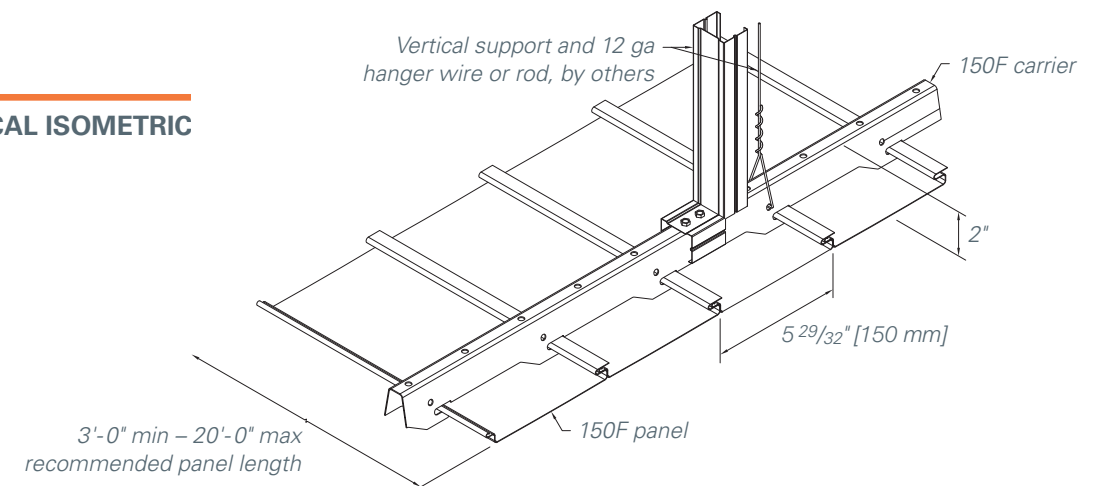

PERFORATION PATTERNS

Standard patterns shown. See page 239 to see all perforation patterns. Scale shown: 1:1, unless otherwise noted.



Non-perforated

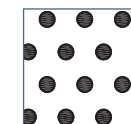

Pattern #124
(Ventilation Panels)

PHYSICAL DATA

Substrate: Aluminum
Warranty: 1 year
Seismic rating: Zones A,B,C,D,E,F
Fire rating: Class A Fire Rated per ASTM E84
 – Painted or anodized metal: Flame spread: ≤ 25, Smoke ≤ 50
Weight: Varies 0.5 – 0.75 lbs./sq.ft.
Wind load: Per code. Designed and tested in accordance with the requirements of the Florida Building Code 5th edition (2014), including the High Velocity Hurricane Zone (HVHZ) provisions and Miami-Dade requirements.
Miami-Dade County, Florida NOA No. 14-1222.04 (expires March 19, 2020)
Recycled content: Up to 92%

BIM

REVIT files available for BIM contributions, see website for details.

LEED V4 CREDITS

EA: Optimize Energy Performance
 MR: Building Product Disclosure
 EQ: Low-Emitting Materials
 EQ: Indoor Air Quality Assessment
 EQ: Daylight

CERTIFICATIONS

GREENGUARD Gold Certified
 HPDs & EPDs – available upon request

EXTERIOR SOFFITS

EXTERIOR – LINEAR
150F – LINEAR METAL SOFFIT SYSTEM

COLORS & FINISHES

Hunter Douglas offers a wide choice of colors and finishes. Some colors and finishes carry a premium price over manufacturer’s standard colors. Custom color matching is available upon request. Please contact Hunter Douglas at 800-366-4327 for minimum quantities and lead times. To request samples, contact us at ceiling.samples@hunterdouglas.com. See website for the most up to date information. Colors are for illustration purposes only.

STANDARD PAINT COLORS – LUXACOTE EXTERIOR PAINT



Lighthouse White 0401
Natural 7080

CUSTOM COLORS

Premium custom colors.



Custom

DECORATED WOOD-LOOK OPTIONS

Powder-coat paint finish (interior and exterior). Formaldehyde-free, Class A composite panel. This finish is recommended for exterior conditions.

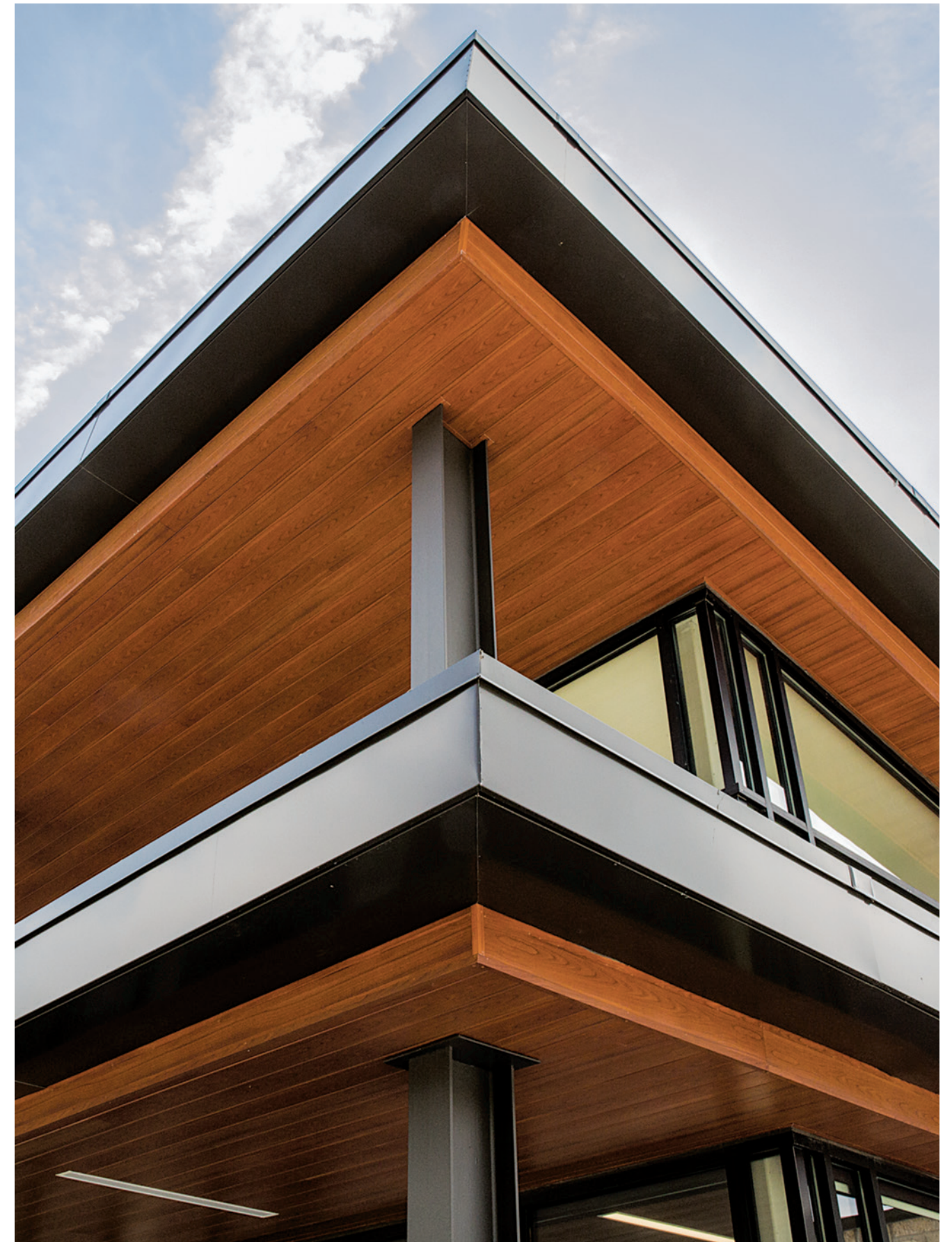

Project: Mercantil Commercebank, Houston, TX; 150F Linear Metal Soffit System Photo credit: Bob Perzel