

LUXALON

Linear Ceilings

Hunter Douglas Luxalon® Linear Ceilings providing interesting possibilities for directional room design. Employ smooth, clean lines or mix sizes, heights and over 40 available colours to create staggered, multi-layered ceiling designs.

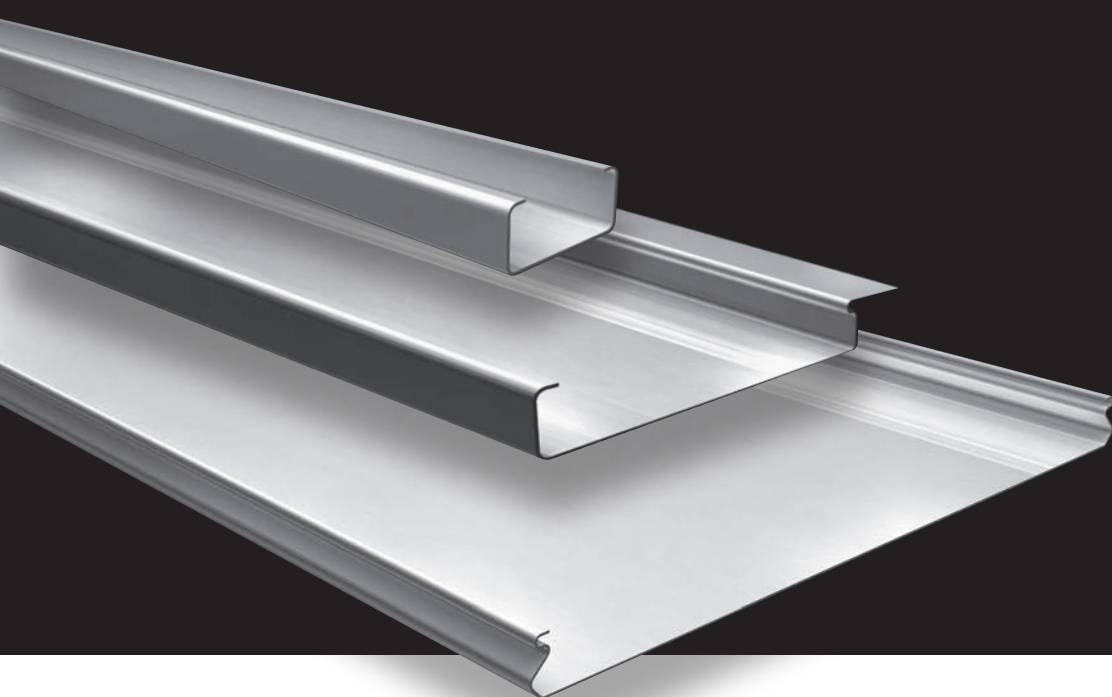

Linear Panel

In line with style



DESIGN FLEXIBILITY

Luxalon® Linear Ceilings provide interesting possibilities for directional room design. Our ceiling systems highlight versatility, allowing a variety of visual effects, including radial and diagonal patterns, finishes and curves. Choose from over 40 available colours and mix and match different sizes and heights to create the perfect look for your project.

DURABILITY

Luxalon® Linear Ceilings are manufactured from durable roll formed aluminium coil, 0.35 mm, 0.5 mm or 0.6 mm, finished with a polyester paint to provide a long, low maintenance life. The coating is stove enamelled in a continuous coil coating process ensuring uniform coating thickness and absolute adhesion. For exterior applications aluminium panels with Luxacote® finish are available.

EASY PLENUM ACCESS

Most panels can be easily demounted by hand allowing easy and full access to services and installation in the plenum.

ACOUSTIC PERFORMANCE

In order to improve the acoustic comfort in a room, the ceiling panels can be perforated with 1, 1.5 or 2 mm round holes. As a standard feature, perforated panels are supplied with a sound absorbing non-woven tissue glued into the panel for enhanced acoustical performance.



No matter your style, our linear ceilings have the looks you love. Whatever your project's needs, our linear ceilings give you the freedom to think inside or outside the box. Our ceiling systems highlight versatility, allowing a variety of visual effects, including radial and diagonal patterns and curves.

<u>CONTENT</u>	<u>Page</u>
Multi-panel	2
CCA Acoustic+ 30BD-30BXD	3
Closed Ceiling 75C-150C-225C	4
84B	5
84C	6
84R	7
70U	8
Acoustics	9 - 12
Material Specifications	12 - 13

ENVIRONMENT

In close cooperation with other members of TAIM eV, Hunter Douglas has established Environmental Product Declarations (EPDs) for both steel and aluminium ceilings. Certificates are available on request.

According to French Regulations DEVL 1101903D of 23 March, 2011 and Amendment DEVL 1104875A of 19 April, 2011, on declaration of VOC emissions to indoor air, Hunter Douglas plain and perforated ceilings with non-woven acoustic fabric, have a VOC classification A+ (lowest class of emissions to indoor air).

Designed to work for you



Production by
Hunter Douglas
Ceiling Center



HunterDouglas 

Multi-panel

PANELS

The Multi-Panel Ceiling System consists of box-shaped panels in 8 varying widths and heights. With this system there is the possibility to create a ceiling design with different widths and heights in one ceiling. The 20 mm joint can be filled with a V-shaped or U-shaped joint profile.

SUSPENSION

The panel carrier (11) is provided with prongs to accommodate the panels in a module of 50 mm or a multiple of this module. Carriers are joined by using the carrier splice (13).

Flexible carriers are available in order to create curved ceilings.

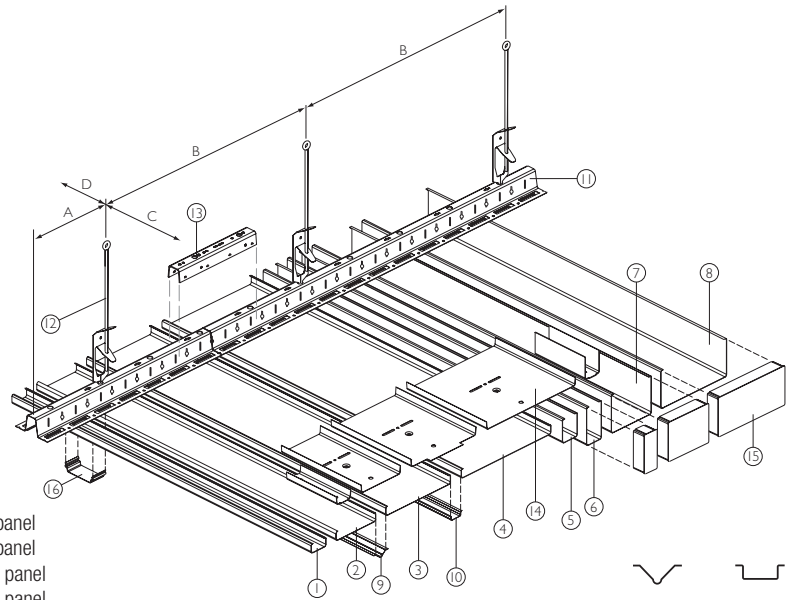

- 1 = 30B panel
- 2 = 80B panel
- 3 = 130B panel
- 4 = 180B panel
- 5 = 30BD panel
- 6 = 30BXD panel
- 7 = 80BXD panel
- 8 = 130BXD panel
- 9 = Recessed V-joint profile
- 10 = Recessed U-joint profile
- 11 = Multi-Panel Carrier
- 12 = Hanger
- 13 = Carrier Splice
- 14 = Panel Splice
- 15 = End Cap
- 16 = Fixing clip

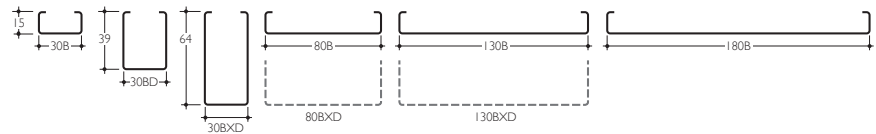
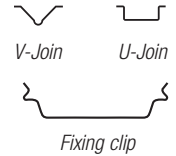

CONSTRUCTION DETAILS

The panels are clipped to a universal multi-panel carrier, creating the opportunity to use panels with different widths and heights in one ceiling.

The standard range of edge profiles can be used for perimeters.

* With open joints the fixing clip (16) should be used in combination with an adaptor panel.

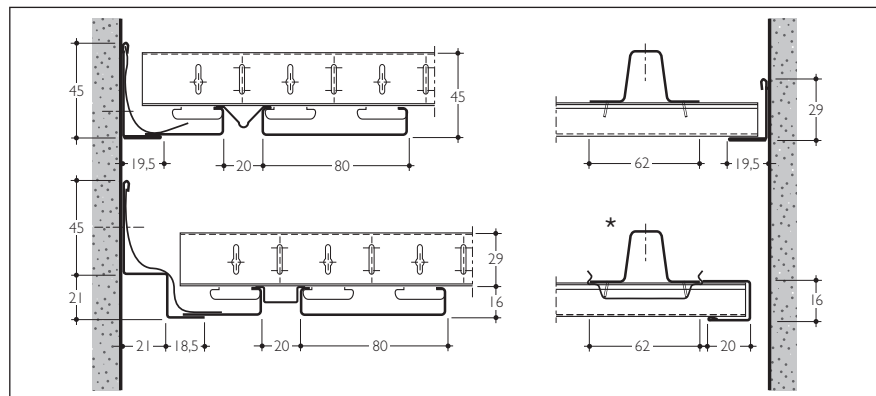

MAXIMUM SPANS

* Minus 200 mm in case of acoustic pads.

Panel type	Carrier Span (mm)		Panel Span (mm)			
	A	B	on 2 carriers		on 3 or more carriers	
			C*	D	C*	D
30BD	300	1200	1800	150	1800	150
30B/80B	300	1700	1550	150	1850	150
130B	300	1700	1450	150	1550	150
180B	300	1700	1350	150	1450	150
BXD	300	1200	1800	150	1800	150

DIMENSIONS

The panels are made to measure in any length from 800 mm up to 6000 mm.

Panels > 6000 mm available on request.

Carriers have a standard length of 5000 mm.

Weights are mentioned in kg.

Panel	30BD	30B	80B	130B	180B	30BXD	80BXD	130BXD
Thickness	0.5	0.35	0.5	0.5	0.6	0.5	0.6	0.6
Module	50	50	100	150	200	50	100	150
Weight incl. join	3.7	1.9	2.1	2.1	2.4	5.1	3.9	3.3
Weight excl. join	3.3	1.5	1.9	1.9	2.2	4.7	3.7	3.1*

*Use of fixing clips optional

MATERIAL REQUIREMENT PER M²

Edge profiles and other accessories depend on individual project requirements.

Figures are based on maximum spans.

	30BD	30B	80B	130B	180B	30BXD	80BXD	130BXD
Panels (lm)	20	20	10	6.67	5	20	10	6.67
Join profiles (lm)	20	20	10	6.67	5	20	10	6.67
Carrier (lm)	0.4	0.55	0.55	0.65	0.69	0.56	0.56	0.56
Carrier splice (pcs)	0.08	0.11	0.11	0.13	0.14	0.11	0.11	0.11
Suspension (pcs)	0.24	0.32	0.32	0.38	0.41	0.46	0.46	0.46
fixing clip (pcs) for use without join profiles								12

CCA Acoustic+ 30BD-30BXD

COMPLETE COVERAGE

Traditional ceilings systems like baffle and ceiling islands offer an acoustic solution, however complete ceiling coverage is not possible. The excellent thermal exchange and acoustic performance of Luxalon® CCA Acoustic+ 30BD and 30BXD enables 100% acoustical ceiling coverage, creating outstanding acoustic comfort and temperature control at levels that cannot be achieved with island or baffle systems.

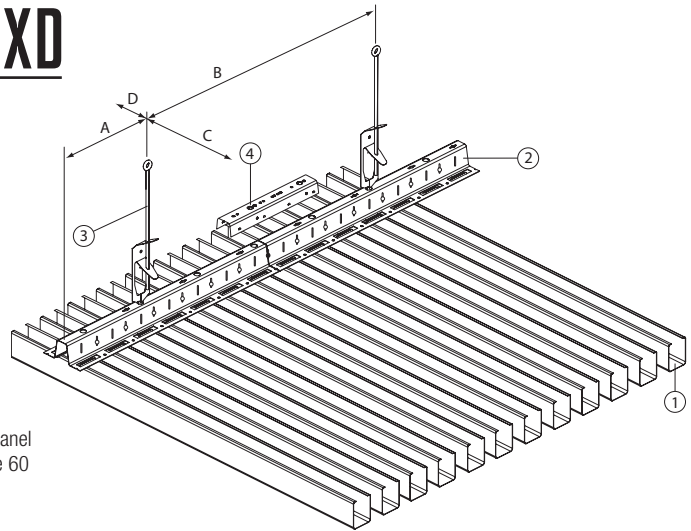

- 1 = 30BD / 30BXD panel
- 2 = Al carrier module 60
- 3 = Hanger
- 4 = Al carrier splice

Panel type	Carrier Span (mm)		Panel Span (mm)			
	A	B	on 2 carriers		on 3 or more carriers	
			C*	D	C*	D
30BD/30BXD	300	1200	1800	150	1800	150

THERMAL ACTIVATION

CCA reaches maximum efficiency if there is no barrier between the concrete structure and the underlying spaces. Independent climate chamber tests have shown that the aluminium used in Luxalon® CCA Acoustic+ 30BD and 30BXD panels and carriers is highly suited for cooling and heating as it functions as a thermal conductor. In combination with the relative openness of this ceiling system (50% openness with complete ceiling coverage), very positive results can be obtained.

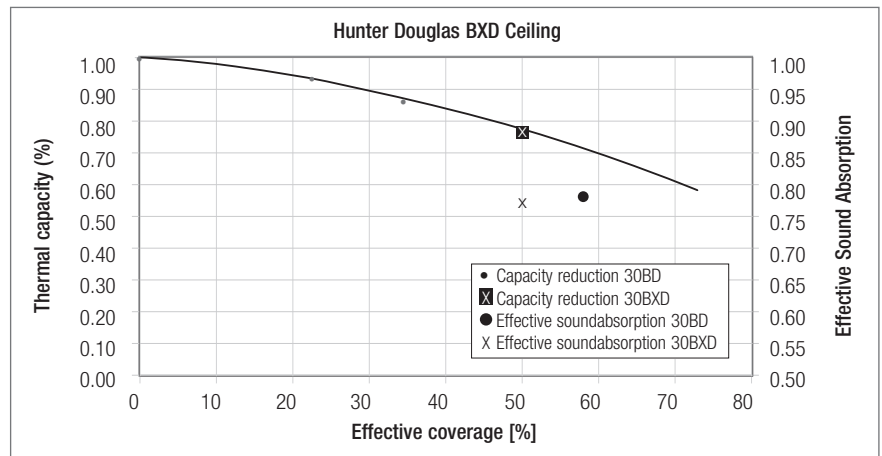

THERMAL CAPACITY

Complete ceiling coverage results in a thermal capacity reduction of only 23% when compared to a bare CCA ceiling. During winter the reduction in the thermal capacity compared to a bare CCA ceiling is 6%, based on complete ceiling coverage.

THERMAL EXCHANGE (Summer situation)

Reduction in capacity of CCA with 30BXD	Unit
2.0	W/m ² .K
23	%

ACOUSTICS

Our extensive experience in acoustic applications with Luxalon® Ceiling Systems has enabled Hunter Douglas to design an optimised CCA solution. Luxalon® CCA Acoustic+ 30BD and 30BXD panels are finished with special fine perforation in combination with acoustic nonwoven fabric and a high-grade sound absorbing filling. The result is an absorption capacity of $\alpha_w = 0.6(H)$ for an acoustically comfortable working environment.

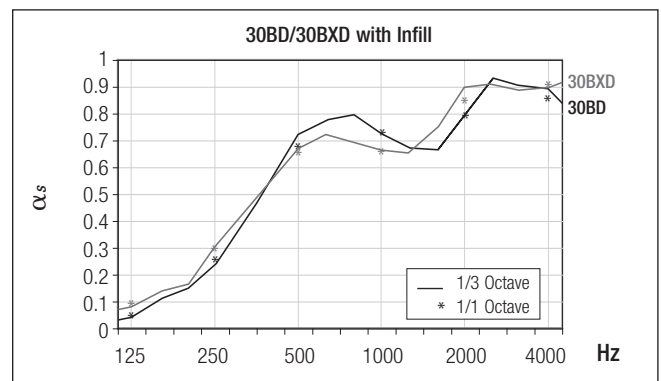

ACOUSTICS

Acoustic+	125	250	500	1000	2000	4000	α_w	NRC
30BD	0.06	0.26	0.69	0.74	0.80	0.87	0.55	0.65
30BXD	0.09	0.30	0.66	0.67	0.85	0.91	0.60	0.65

The values are based on a plenum height of 70 mm. For the graphic reproduction of acoustic values see curve 30BD and 30BXD in the above graph. Tested by Peutz, test report no.: A 1846-1E-RA and test report no.: BA 1164-2E-RA

75C-150C-225C

PANELS

This ceiling system combines three widths of panels which are distinguished from other Hunter Douglas systems by their bevelled edges and when installed produces a closed smooth appearance.

SUSPENSION

The panels can be fixed to a universal carrier for all three widths, all the same or mixed. The panels are joined together using a panel splice whilst the carriers use the standard carrier connector. Adaptor panels shall be locked by the adaptor clip.

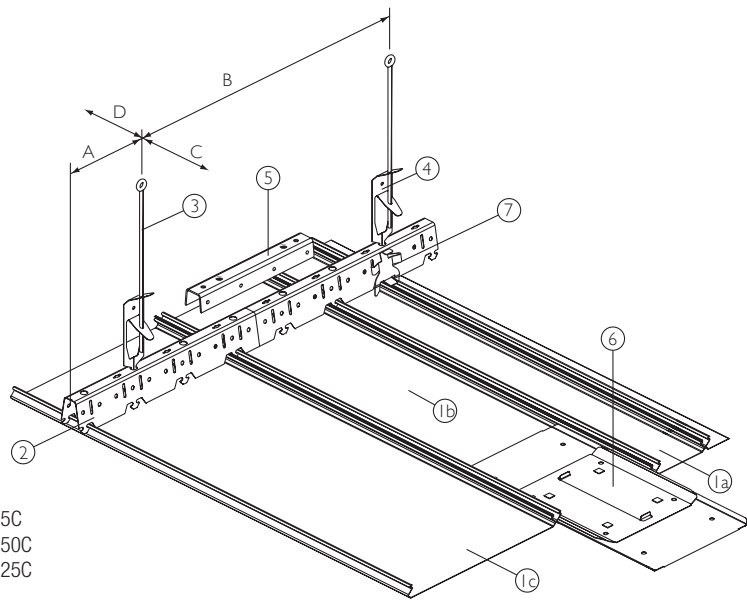

- 1a = Panel 75C
- 1b = Panel 150C
- 1c = Panel 225C
- 2 = Carrier
- 3 = Rod hanger
- 4 = Suspension adjustment spring
- 5 = Carrier splice
- 6 = Panel splice
- 7 = Adaptor clip

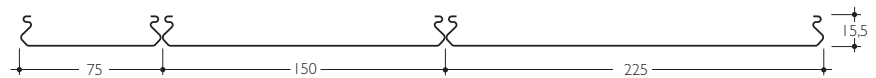

CONSTRUCTION DETAILS

The standard range of edge profiles can be used.

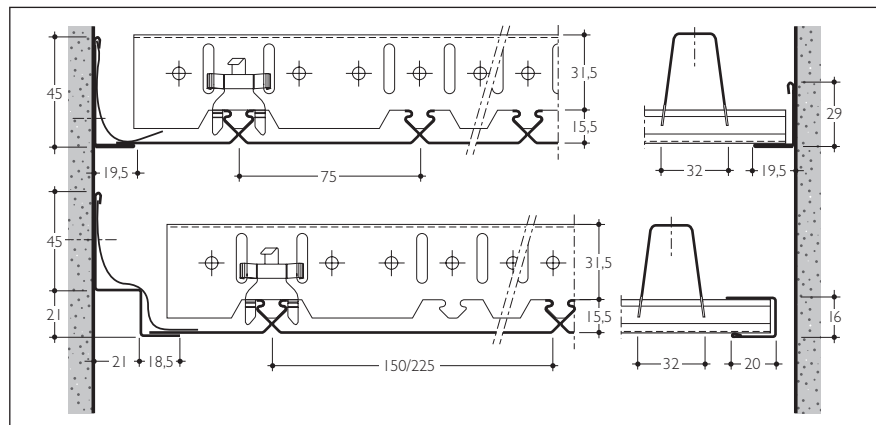

MAXIMUM SPANS

* minus 200 mm in case of acoustic pads.

Panel type	Carrier Span (mm)		Panel Span (mm)	
	A	B	C*	D
75C	300	1700	1250	150
150C	300	1700	1000	150
225C	300	1700	1000	150

DIMENSIONS & WEIGHTS

The panels can be supplied in any length from 800 mm up to 6000 mm, carriers have a standard length of 5000 mm. Panels > 6000 mm available on request.

Panel	Module	Material	Weight kg/m ²
15.5 x 75	75	0.5 Alu	2.13 kg
15.5 x 150	150	0.5 Alu	1.96 kg
15.5 x 225	225	0.6 Alu	2.19 kg

MATERIAL REQUIREMENT PER M²

Edge profiles and other accessories depend on individual project requirements.

	Unit	75C	150C	225C
Panels	lm	13.33	6.67	4.44
Carriers	lm	0.80	1.0	1.0
Carrier splice	pcs	0.16	0.2	0.2

84B

PANELS

The 84B ceiling system consists of box shaped panels (1) which can be easily clipped on a carrier (2). Panels can be joined by using the panel splice (5). The 16 mm joint can be filled with a flush join profile (6) to form a closed ceiling appearance.

SUSPENSION

The panel carrier (2) is provided with prongs to accommodate the panels in a standard module of 100 mm. Carriers are connected by using the carrier splice (4).

The system is designed to withstand the impact of all types of ball sports (DIN 18038). It is necessary to use the fixing clips and adapt the carrier span.

Flexible carriers are available in order to create a curved ceiling. To achieve a different module (90-125 mm) a non-standard carrier is available.

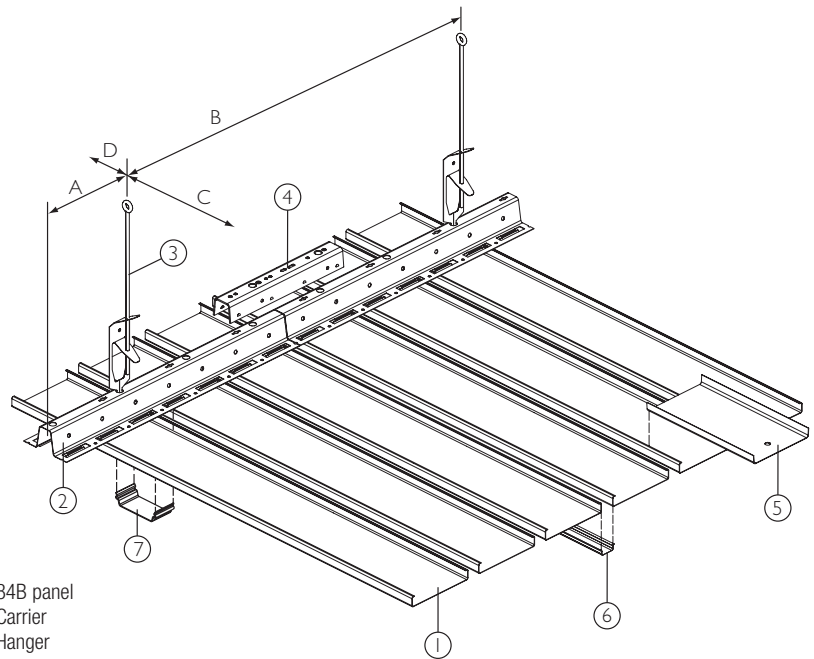

- 1 = 84B panel
- 2 = Carrier
- 3 = Hanger
- 4 = Carrier splice
- 5 = Panel splice
- 6 = U-joint profile
- 7 = Fixing clip

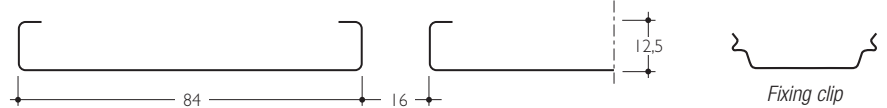

CONSTRUCTION DETAILS

The standard range of edge profiles can be used.

* With open joints the fixing clip (7) shall be used in combination with an adaptor panel.

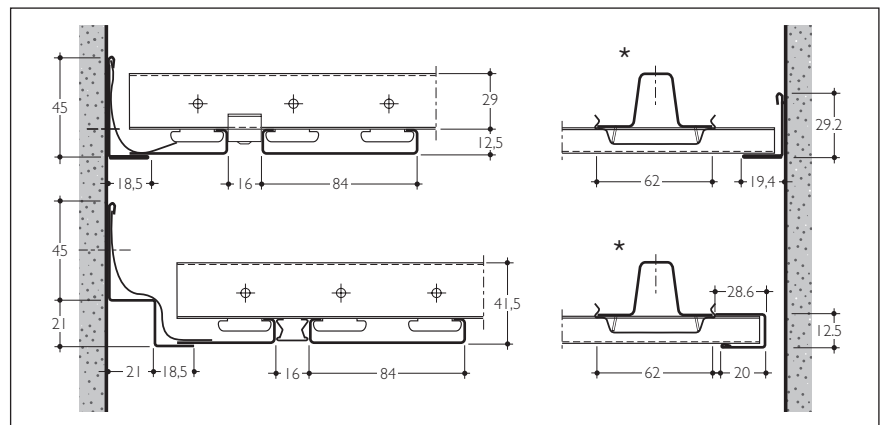

MAXIMUM SPANS

* Minus 200 mm in case of acoustic pads.

** Sporthall ceiling (based on DIN 18038 Sporthall standards)

Panel type	Carrier Span (mm)		Panel Span (mm)			
	A	B	on 2 carriers		on 3 or more carriers	
			C*	D	C*	D
84B	300	1700	1450	150	1650	150
84B**	300	700	600	150	600	150

DIMENSIONS & WEIGHTS

* Based on panels installed on 3 or more carriers. The panels are made to measure in any length from 800 mm up to 6000 mm.

Panels > 6000 mm available on request.

Carriers have a standard length of 5000 mm.

Panel	Width (mm)	Module (mm)	Min. length (mm)	Max. length (mm)	Weight panels & carriers/m ² *	
					Steel carrier	Alu carrier
84B	84	100	800	6000	1.8 kg	1.7 kg

MATERIAL REQUIREMENT PER M²

The required number of components depend on individual project requirements.

Figures are based on maximum spans.

	Unit	Linear 84B system	Sports Hall Ceiling
Panels	lm	10	10
Carriers	lm	0.61	1.67
Carrier splice	pc	0.12	0.33
Suspension	pc	0.36	2.38
Fixing clips	pc		16.7

84C

PANELS

The 84C closed ceiling system consists of box shaped panels (1) which can be easily clipped on a carrier (2). The 84 mm wide panels feature a 24 mm wide flange that closes-off the 16 mm joint between the panels (module 100 mm).

SUSPENSION

The panel carrier (2) is provided with prongs to accommodate the panels in a module of 100 mm. Carriers are connected by using the carrier splice (4).

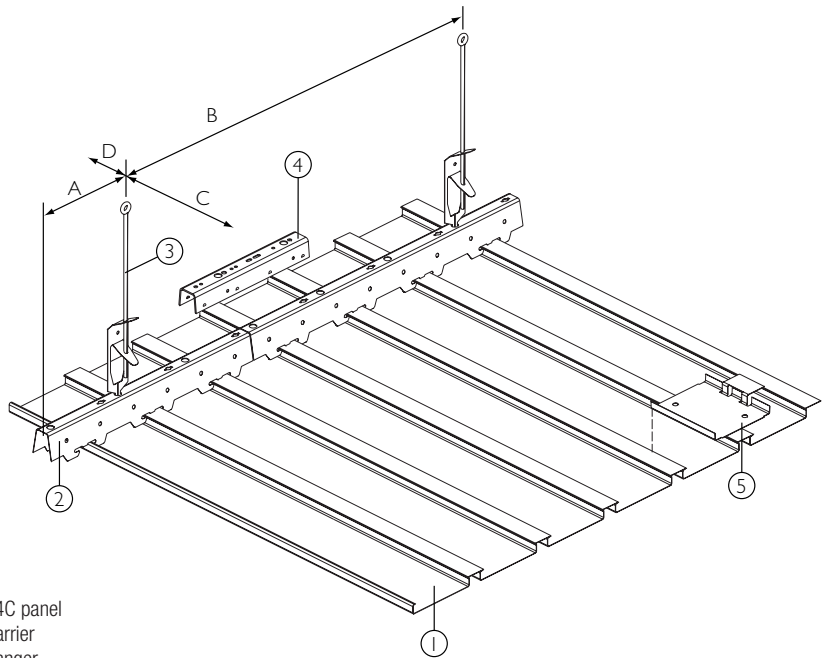

- 1 = 84C panel
- 2 = Carrier
- 3 = Hanger
- 4 = Carrier splice
- 5 = Panel splice

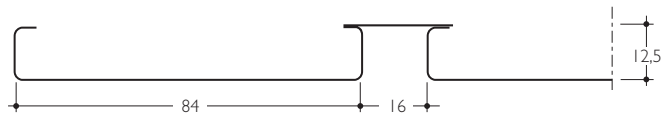

CONSTRUCTION DETAILS

The standard range of edge profiles can be used.

* A locking clip is necessary when no edge-profile springs are used.

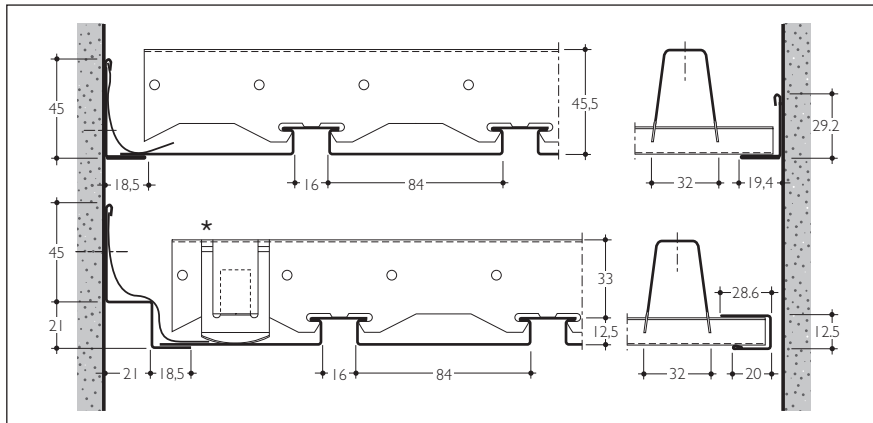

MAXIMUM SPANS

* Minus 200 mm in case of acoustic pads.

Panel type	Carrier Span (mm)		Panel Span (mm)			
	A	B	on 2 carriers		on 3 or more carriers	
			C*	D	C*	D
84C	300	1300	1600	150	1800	150

DIMENSIONS & WEIGHTS

* Based on panels installed on 3 or more carriers. The panels are made to measure in any length from 800 mm up to 6000 mm.

Panels > 6000 mm available on request.

Carriers have a standard length of 5000 mm.

Panel	Width (mm)	Module (mm)	Min. length (mm)	Max. length (mm)	Weight panels & carriers/m ² *	
					Steel carrier	Alu carrier
84C	84	100	800	6000	2.2 kg	2.1 kg

MATERIAL REQUIREMENT PER M²

The required number of components depend on individual project requirements.

Figures are based on maximum spans.

	Unit	Linear 84B system
Panels	lm	10
Carriers	lm	0.56
Carrier splice	pc	0.11
Suspension	pc	0.43

84R

PANELS

The 84R ceiling system consists of round edged panels (1) which can be easily clipped on a carrier (3). Panels can be joined using the panel splice (6). The 16 mm joint can be filled with a flush join profile (2) to form a closed ceiling appearance. The 16 mm joint can be filled with a flush join profile (2) to form a closed ceiling appearance.

SUSPENSION

The panel carrier (3) is provided with prongs to accommodate the panels in a standard module of 100 mm. All carriers have a standard length of 5000 mm and are connected by using the carrier splice (5). Curved ceilings can be achieved by using a flexible carrier or by curving the panels.

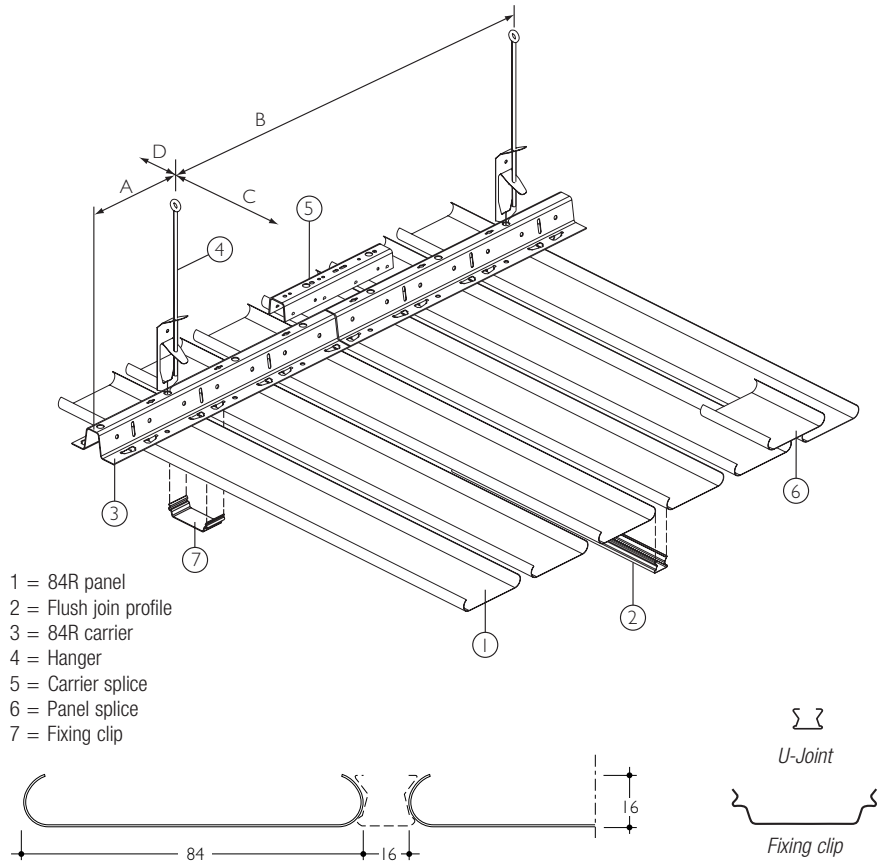

- 1 = 84R panel
- 2 = Flush join profile
- 3 = 84R carrier
- 4 = Hanger
- 5 = Carrier splice
- 6 = Panel splice
- 7 = Fixing clip

Curved ceilings can be achieved by using a flexible carrier or by curving the panels.

CONSTRUCTION DETAILS

The standard range of edge profiles can be used as perimeters.

* With open joints the fixing clip (7) shall be used in combination with an adaptor panel.

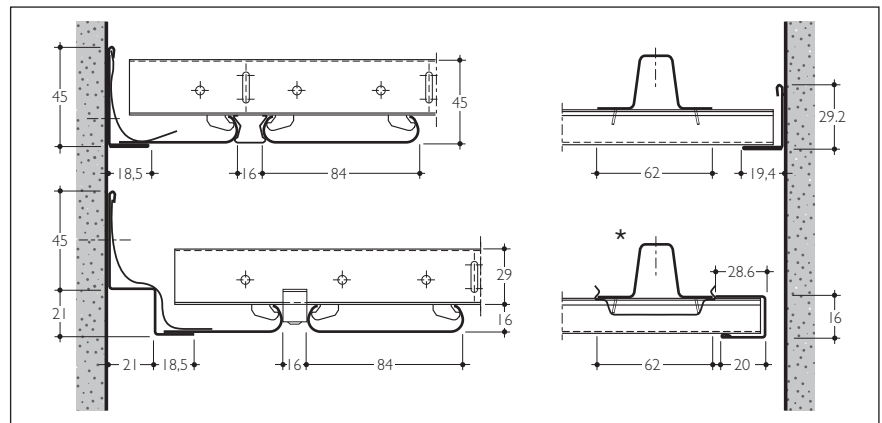

MAXIMUM SPANS

* Minus 200 mm in case of acoustic pads.

Panel type	Carrier Span (mm)		Panel Span (mm)			
	A	B	on 2 carriers		on 3 or more carriers	
			C*	D	C*	D
84R	300	1700	1500	150	1700	150

DIMENSIONS & WEIGHTS

* Based on panels installed on 3 or more carriers. The panels are made to measure in any length from 800 mm up to 6000 mm. Panels > 6000 mm available on request.

Panel	Width (mm)	Module (mm)	Min. length (mm)	Max. length (mm)	Weight panels & carriers/m ² *			
					Steel carrier		Alu carrier	
					Excl joints	Incl joints	Excl joints	Incl joints
84R	84	100	800	6000	1.8 kg	2.3 kg	1.7 kg	2.2 kg

MATERIAL REQUIREMENT PER M²

The required number of components depend on individual project requirements. Figures are based on maximum spans.

	Unit	Linear 84R system
Panels	lm	10
Join profiles	lm	10
Carriers	lm	0.59
Carrier splice	pc	0.12
Suspension	pc	0.35

70U

PANELS

The 70U ceiling system consists of box shaped, 70 mm wide steel or aluminium panels (1) which are easily clipped on the 70U carrier (2). Panels are joined by using the panel splice (5).

SUSPENSION

The panel carrier (2) is provided with prongs to accommodate the panels in a module of 100 mm. Carriers are connected by using the carrier splice (4). Locking clips (6) are fitted on the carrier between the panels in order to fully secure the panels.

The system is designed to withstand the impact of all types of ball sports (DIN 18032). It is necessary to use the fixing clips and adapt the carrier span.

Aluminium panels in combination with aluminium carriers make the system suitable for **swimming pools** and **exterior applications**.

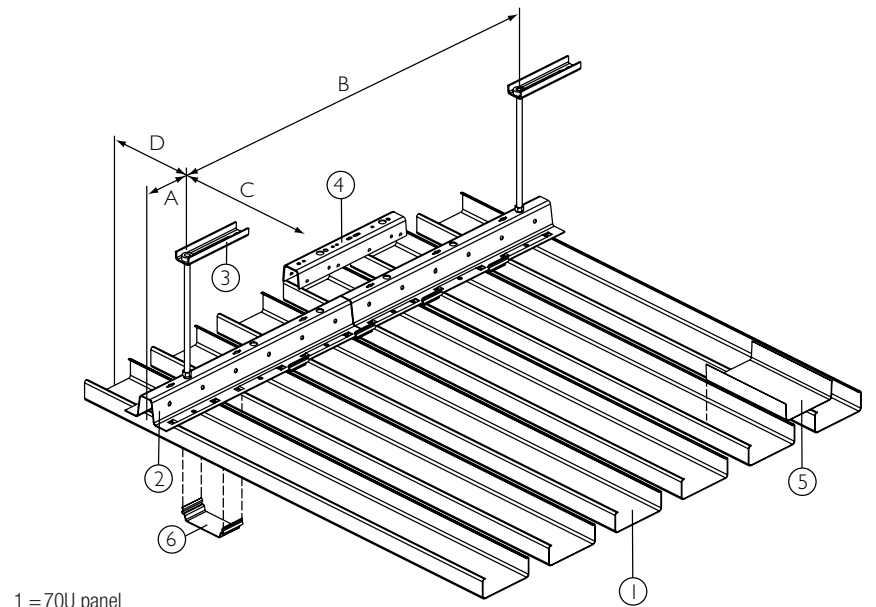

- 1 = 70U panel
- 2 = Carrier
- 3 = Hanger
- 4 = Carrier splice
- 5 = Panel splice
- 6 = Fixing clip



CONSTRUCTION DETAILS

The standard range of edge profiles can be used for perimeters.

* Panel fixing clip to be used in all joints to secure the panels.

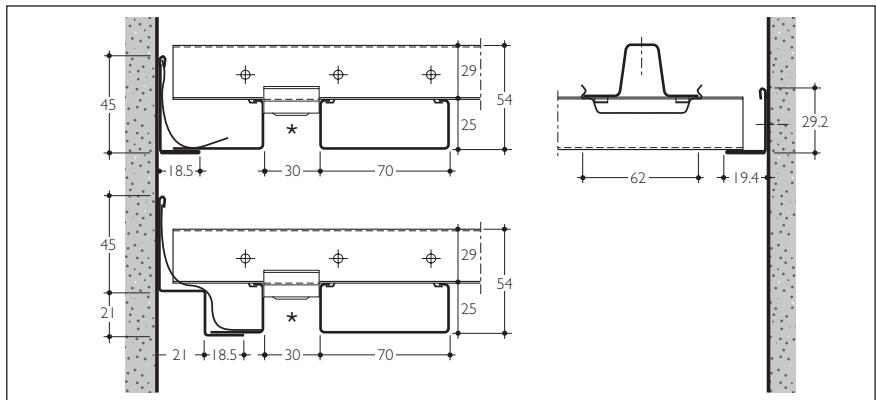

MAXIMUM SPANS

* Minus 200 mm in case of acoustic pads.
Standard Ceiling not submitted to any additional loads.

Ceiling applied in sport halls and submitted to ball loads. The spans depend on the loads that are applied on the ceiling. Results are based on DIN18032 sport hall standards.

Panel type 70U	Carrier Span (mm)				Panel Span (mm)	
	Steel 1.0		Alu 0.95		C*	D
	A	B	A	B		
Alu 0.8	300	1700	300	1350	1500	150
Steel 0.8	300	1400	N.A.	N.A.	1500	150

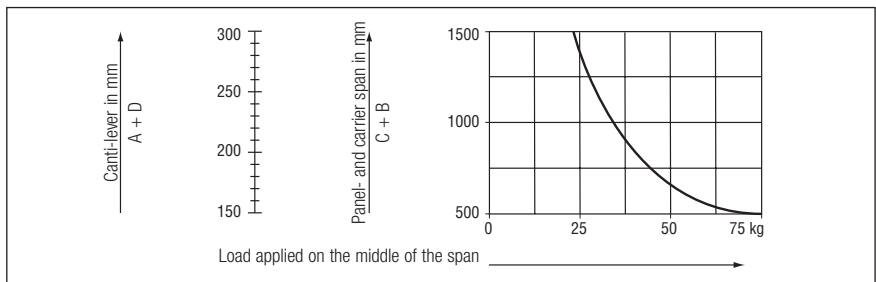

DIMENSIONS & WEIGHTS

The panels are made from 0.8 mm aluminium or steel and can be supplied in lengths from 800 mm up to 6000 mm.

Carriers have a standard length of 5000 mm.

Panel	Width (mm)	Module (mm)	Min. length (mm)	Max. length (mm)	Weight panels & carriers/m ² *	
					Steel carrier	Alu carrier
Alu 0.8	70	100	800	6000	3.27 kg	2.9 kg
Steel 0.8	70	100	800	6000	8.3 kg	N.A.

Acoustics

ACOUSTIC PERFORMANCE

In order to improve interior sound control, the Luxalon® panels can be supplied perforated. As a standard feature, perforated panels are supplied with a soundabsorbing non-woven tissue glued into the panel for enhanced acoustical performance.

mm	30BD	75C	80B	84B	84C	84R	130B	150C	180B	225C	BXD
Ø 1	•	•	•	•	•	•					
Ø 1.5										•	•
Ø 2	•		•	•	•	•	•	•	•		
Ø 2*										•	

Flush join profile is available for 84R with ventilation holes dimensions 3 x 7 mm, c.t.c 10.5 mm.
30B and 70U are not available as perforated panels.

PERFORATION PATTERNS

Ø 1 mm ⇄ 2 ⇄ 3.46 Openness 23%	Ø 1.5 mm ⇄ 3 ⇄ 5.2 Openness 23%	Ø 2 mm ⇄ 8.66 ⇄ 5 Openness 16%	Ø 2* mm ⇄ 5 ⇄ 8.66 Openness 16%

PLAIN BORDERS

Panels have a nominal plain border along the longitudinal panel direction in order to assure maximum flatness and product stability:

30BD standard	30BD on request	75C-150C	225C
30/80/130BXD	80B/130B/180B	84B	84C
	84R		

EDGE PROFILES

Clip-on U-profile Alu 0.4 mm (24.8 x 12.5 x 14)	Clip-on U-profile Alu 0.4 mm (28.6 x 16 x 20)	Wall L-profile Alu 0.5 mm (29.2 x 19.4)	Wall L-profile Fe/Alu 0.8 mm (45 x 18.5)	Wall W-profile Fe/Alu 0.8 mm (45 x 21 x 21 x 18.5)

SOUND ABSORPTION DATA

80B, 130B, 180B

- Curve 1*

80B panels perforated with Ø1 mm holes, module 100 mm, open joints.
The reverse side of the panels is provided with black non-woven tissue glued over the whole perforated area. Plenum depth is 200 mm.

- Curve 2**

80B panels perforated with Ø2 mm holes, module 100 mm, closed joints.
The reverse side of the panels is provided with black non-woven tissue glued over the whole perforated area. Plenum depth is 200 mm

- Curve 3**

130B panels perforated with Ø2 mm holes, module 130 mm, closed joints.
The reverse side of the panels is provided with black non-woven tissue glued over the whole perforated area. Plenum depth is 200 mm.

- Curve 4**

180B panels perforated with Ø2 mm holes, module 180 mm, closed joints.
The reverse side of the panels is provided with black non-woven tissue glued over the whole perforated area. Plenum depth is 200 mm.

*Tested by TNO Delft; test report no: TPD-HAG-RPT-92-0038

**Tested by Peutz; test report no: A1709

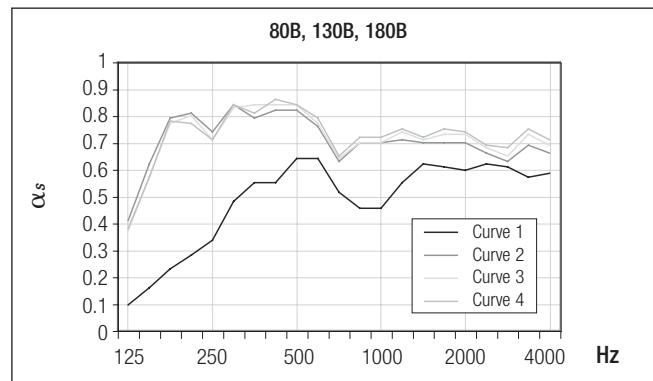

Freq. Hz.	125	250	500	1000	2000	4000	α_w	NRC
Curve 1	0.10	0.34	0.61	0.47	0.60	0.59	0.55	0.50
Curve 2	0.41	0.74	0.82	0.70	0.70	0.66	0.75	0.75
Curve 3	0.37	0.71	0.84	0.70	0.73	0.69	0.75	0.75
Curve 4	0.38	0.71	0.84	0.72	0.74	0.71	0.75	0.75

Combination 30BXD, 80BXD and 130BXD panels Without joint profiles

Combination of 30BXD panels, 80BXD panels and 130BXD panels,
joint width 20 mm, without joint profile between panels

PEUTZ A 2558-1E-RA.

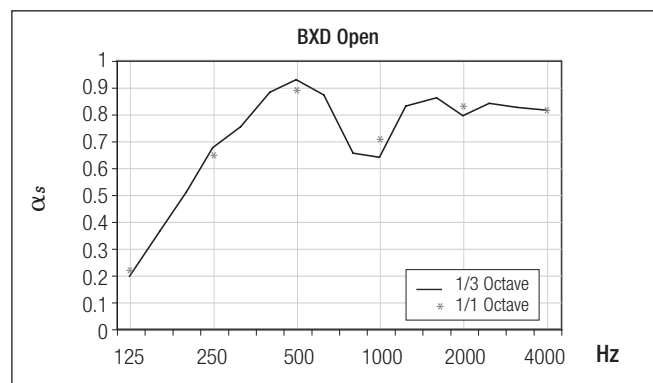

Freq. Hz.	125	250	500	1000	2000	4000	α_w	NRC
1/1 Octave	0.16	0.60	0.85	0.66	0.79	0.77	0.75	0.70

Combination 30BXD, 80BXD and 130BXD panels With joint profiles

Combination of 30BXD panels, 80BXD panels and 130BXD panels,
joint width 20 mm, with joint profile between panels

PEUTZ A 2558-1E-RA

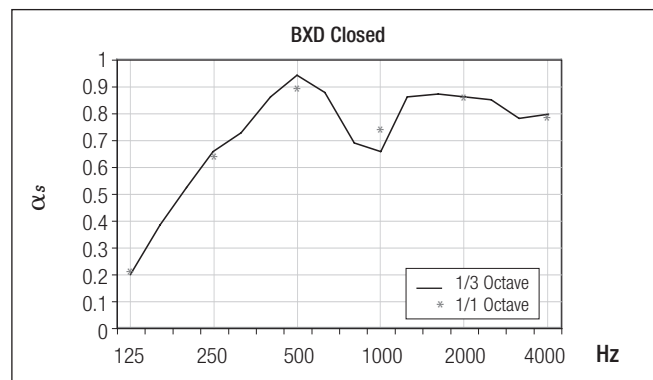

Freq. Hz.	125	250	500	1000	2000	4000	α_w	NRC
1/1 Octave	0.22	0.64	0.89	0.74	0.86	0.79	0.85	0.80

SOUND ABSORPTION DATA

75C, 150C, 225C

- Curve 1*

75C panels with Ø1 mm holes, module 75 mm, closed joints. The reverse side of the panels is provided with black non-woven tissue glued over the whole perforated area. Plenum depth is 200 mm.

- Curve 2*

150C panels with Ø2 mm holes, module 150 mm, closed joints. The reverse side of the panels is provided with black non-woven tissue glued over the whole perforated area. Plenum depth is 200 mm.

- Curve 3**

225C panels with Ø1.5 mm holes, module 225 mm, closed joints. The reverse side of the panels is provided with black non-woven tissue glued over the whole perforated area. Plenum depth is 200 mm.

- Curve 4**

225C panels with Ø2 mm holes, module 225 mm, closed joints. The reverse side of the panels is provided with black non-woven tissue glued over the whole perforated area. Plenum depth is 200 mm.

*Tested by TNO Delft; test report no: TDP-HAG-RPT-92-0038

**Tested by Peutz; test report no: A1709

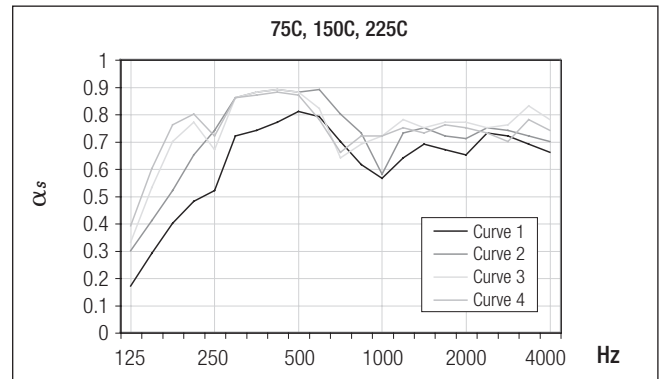

Freq. Hz.	125	250	500	1000	2000	4000	α_w	NRC
Curve 1	0.22	0.57	0.79	0.57	0.69	0.69	0.65	0.65
Curve 2	0.34	0.75	0.88	0.68	0.71	0.71	0.75	0.80
Curve 3	0.22	0.67	0.88	0.72	0.77	0.78	0.75	0.75
Curve 4	0.39	0.72	0.87	0.72	0.75	0.74	0.75	0.75

84B

- Curve 1*

84B panels, perforated with Ø2 mm holes, module 100 mm, open joints. The reverse side of the panels is provided with black non-woven tissue glued over the whole perforated area. Plenum depth is 200 mm.

- Curve 2*

84B panels, perforated with Ø2 mm holes, module 100 mm, open joints. Plus additional 25 mm thick mineral wool pads with a density of approx. 22 kg/m³. Plenum depth is 200 mm.

- Curve 3*

84B plain panels, open joints, module 100 mm. Plus additional 25 mm thick mineral wool pads with a density of approx. 22 kg/m³. Plenum depth is 200 mm.

*Tested by TNO Delft; test report no. TPD-NAG-RPT-920038 and 007293.

These figures are partly based on 80B test results which are assumed as being equal for 84B.

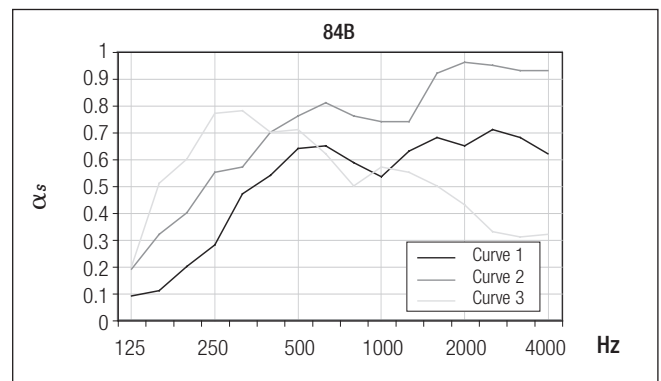

Freq. Hz.	125	250	500	1000	2000	4000	α_w	NRC
Curve 1	0.10	0.32	0.61	0.54	0.68	0.64	-	0.50
Curve 2	0.19	0.55	0.76	0.74	0.96	0.93	-	0.75
Curve 3	0.20	0.77	0.71	0.57	0.43	0.32	-	0.65

84R

- Curve 1

84R panels with Ø2 mm holes, module 100 mm, closed joints. The reverse side of the panels is provided with black non-woven tissue glued over the whole perforated area. Plenum depth is 200 mm.

Tested by Peutz; test report no: A1709

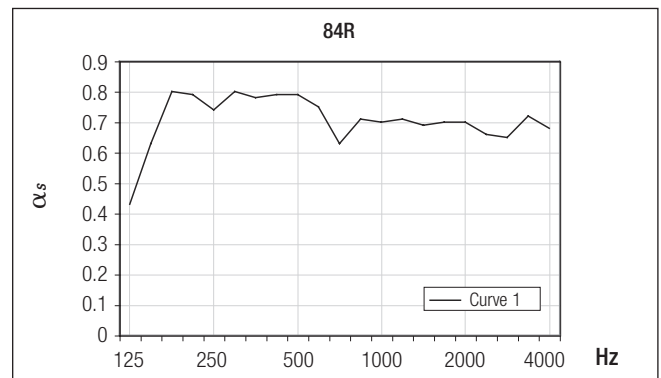

Freq. Hz.	125	250	500	1000	2000	4000	α_w	NRC
Curve 1	0.43	0.74	0.79	0.70	0.70	0.68	0.75	0.75

Acoustics

SOUND ABSORPTION DATA

84C

- Curve 1

84C panels, perforated with Ø2 mm holes, closed joints, module 100 mm. The reverse side of the panels is provided with black non-woven tissue glued over the whole perforated area. Plenum depth is 200 mm.

- Curve 2

84C panels, perforated with Ø2 mm holes, closed joints, module 100 mm. Plus additional 25 mm thick mineral wool pads with a density of approx. 12 kg/m³. Plenum depth is 200 mm.

- Curve 3

84C panels, perforated with Ø1 mm holes, closed joints, module 100 mm. The reverse side of the panels is provided with black non-woven tissue glued over the whole perforated area. Plenum depth is 200 mm.

- Curve 4

84C panels, perforated with Ø1 mm holes, closed joints, module 100 mm. Plus additional 25 mm thick mineral wool pads with a density of approx. 12 kg/m³. Plenum depth is 200 mm.

Tested by TNO Delft; test report no: TPD-HAG-RPT-920039/920038

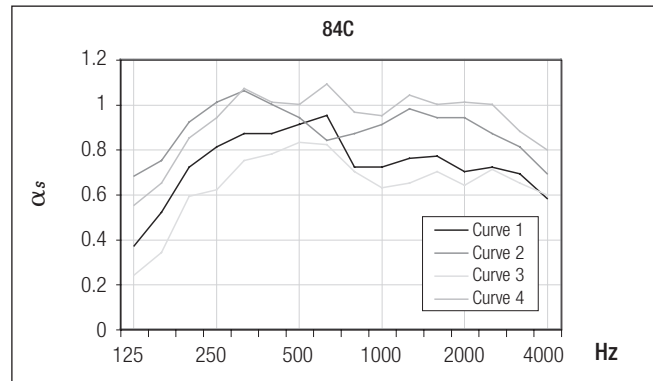

Freq. Hz.	125	250	500	1000	2000	4000	α_w	NRC
Curve 1	0.41	0.80	0.91	0.73	0.73	0.62	-	0.75
Curve 2	0.64	1.00	0.98	0.91	0.92	0.73	-	0.95
Curve 3	0.29	0.65	0.82	0.62	0.68	0.60	-	0.65
Curve 4	0.55	0.95	1.03	0.96	1.00	0.82	-	0.95

30BD, 70U

- Curve 1

70U plain panels, module 100, open joints of 30 mm. Plus additional 25 mm thick mineral wool pads with a density of approx. 55 kg/m³. Plenum depth is 200 mm.

- Curve 2

30BD panels, perforated with Ø2 mm holes, module 50, closed joints. The reverse side of the panels is provided with black non-woven tissue glued over the whole perforated area. Plenum depth is 200 mm.

- Curve 3

30BD panels, side-perforated with Ø2 mm holes, closed joints, module 50 mm. The reverse side of the panels is provided with black non-woven tissue glued over the whole perforated area. Plenum depth is 200 mm.

Tested by Peutz; test report no: MA 82 and A1709

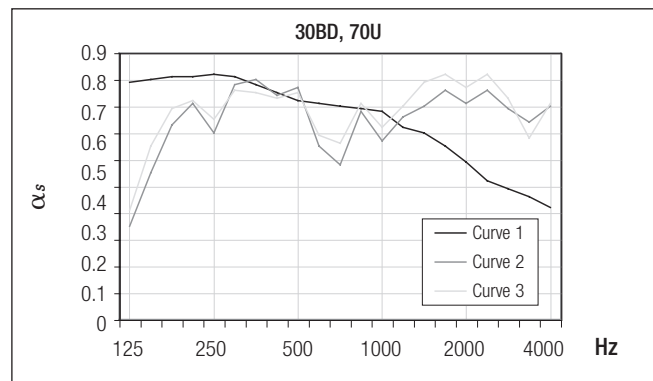

Freq. Hz.	125	250	500	1000	2000	4000	α_w	NRC
Curve 1	0.89	0.92	0.82	0.78	0.59	0.42	-	0.80
Curve 2	0.35	0.70	0.87	0.67	0.81	0.80	0.75	0.75
Curve 3	0.41	0.75	0.85	0.72	0.87	0.81	0.80	0.80

Material specifications



Printed on
EU Ecolabel
certified paper



We are dedicated manufacturing a sustainable product. Our paint and aluminium melting processes are considered to be one of the industry standards in terms of clean production processes. All aluminium products are 100% recyclable at the end of their lifecycle.



Our proprietary coil-coating process ensures ceiling panels get a superb finish. Independent tests have proven the excellent performance characteristics of Luxacote®.



The Dutch Green Building Council (DGBC) was founded in 2008 in the Netherlands as a market initiative. The aim was to make Sustainability in the building industry measurable by developing a sustainability label allowing for the uniform rating of buildings throughout the Netherlands.

Material specifications

FIRE BEHAVIOUR

Luxalon® metal suspended ceilings are classified incombustible and will therefore not contribute to possible fires. When ceilings however need to protect the structural integrity of the building, Luxalon® Ceilings offer a range of practical and tested solutions with regards to fire stability. Further information is available on request.

COLOUR RANGE

The standard Hunter Douglas interior and exterior colour range for Luxalon® Linear Ceiling Systems includes several different colours and finishes. See colour chart. Any other (RAL or NCS) colour is available on request.

CURVED CEILING POSSIBILITIES

Flexible carriers: Multipanel, 84B, 84R, 70U / Curved panels: 84R

SPORTHALL CEILING

The 70U and 84B system with metal panels and carriers makes the system perfectly suitable for applications in sporthalls.

EXTERIOR USE

All linear ceilings ensure durability in exterior building applications. Our proprietary coil-coating process ensures ceiling panels get a superb finish. Independent tests have proven the excellent performance characteristics of Luxacote®. The topcoat contains a solid UV filter that guarantees perfect colourfastness and gloss stability.

The topcoat also offers better resistance against scratches with a structure that resists and masks any minor damage that may occur during installation, resulting in a high abrasion resistance. The alloy and pre-treatment also offers optimal resistance to corrosion.



HUNTER DOUGLAS ARCHITECTURAL PROJECTS

In the last 50 years, we've been fortunate enough to help turn countless innovative sketches into innovative buildings. With major operation centres in Europe, North America, Latin America, Asia and Australia, we've contributed to thousands of high-profile projects, from retail and commercial facilities to major transit centres and government buildings.



ARCHITECTURAL SERVICES

We support our business partners with a wide range of technical consulting and support services for architects, developers and installers. We assist architects and developers with recommendations regarding materials, shapes and dimensions, colours and finishes. We also help creating design proposals, visualisations and mounting drawings. Our services to installers range from providing detailed installation drawings and instructions to training installers and advising on the building site.

Not only are the world's architects and designers our partners, they're our inspiration. They continue to raise the bar for excellence. We create products that help bring their visions to life: Window Coverings, Ceilings, Sun Control Systems and Façades.

Designed
to work for you

Learn More

- Contact our Sales office
- www.hunterdouglasarchitectural.com

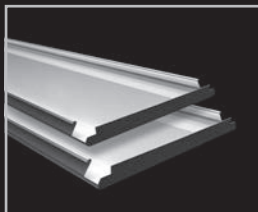

Wide Panel

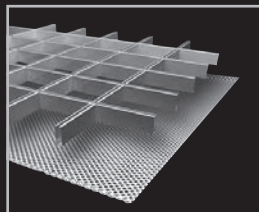

Cell | Stretch metal

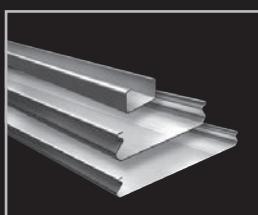

Linear

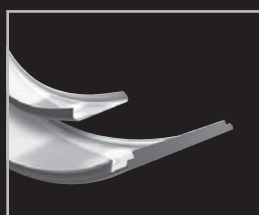

Curved



Screen

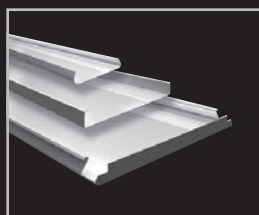

Exterior

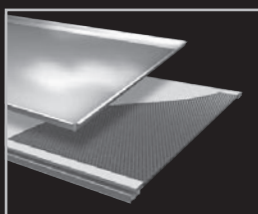

Tiles | XLnt panel

- Belgium
- Bulgaria
- Croatia / Slovenia
- Czech Republic
- Denmark
- France
- Germany
- Greece
- Hungary
- Italy
- The Netherlands
- Norway
- Poland
- Portugal
- Romania
- Russia
- Serbia
- Slovakia
- Spain
- Sweden
- Switzerland
- Turkey
- United Kingdom
- Africa
- Middle East

- Asia
- Australia
- Latin America
- North America

Hunter Douglas Architectural

2, Piekstraat
P.O. Box 5072 - 3008 AB Rotterdam
The Netherlands
Tel. +31 (0)10 - 486 99 11
Fax +31 (0)10 - 484 79 10
www.hunterdouglasarchitectural.com